

HE1U-2524-BBLVD

High Efficiency 1U AC to DC Power Supply Owners Guide

(These instructions are intended for use by a technician familiar with electronic products)

- Integrated Low Voltage Disconnect
- Autorange Input Voltage 90 to 264 VAC
- Remote control ON/OFF
- DC-OK TTL signal
- Short Circuit / Overload / Over Voltage / Over Temperature Protection
- Manual Battery Disconnect Switch
- 3 year warranty



DESCRIPTION

The HE1U-2524-BBLVD is a Heavy Duty AC to DC 750 Watt Power Supply with a low voltage disconnect in a 1U chassis. The HE1U-2524-BBLVD comes with power factor correction, and four layers of protection against overload, over voltage, over temperature, and short circuit. This model also comes with a manual battery disconnect switch, internal power supply ON/OFF remote control, and DC-OK. The HE1U-2524-BBLVD comes with a 3 year warranty.

SPECIFICATIONS

Output Voltage	27.6 VDC
Output Voltage Tolerance	+/- 1 %
Output Amperage	25 Amps max.
Maximum Power, continuous	750 Watts
Maximum Ripple and Noise	150 mV p-p max
Input Voltage	90 to 264 VAC
Input Frequency Range	47-63 Hz
Maximum AC Current	8.2 Amps/115 VAC; 3.9 Amps/230 VAC
Typical Efficiency	90.5 %
Max Inrush Current, single cycle	25 Amps / 115 VAC, 40 Amps / 230VAC
Short Circuit Protection	Constant Current Limiting
Overload Protection (operates)	typical 105-125 %
Line Regulation	+/- 0.5 %
Load Regulation	+/- 0.5 %
Over Temperature	>195 F (90 C) auto output shutdown
Rise Time following ON	50 mS
Hold Time following OFF	16 mS
Working Temperature Range	-22 F to +158 F (-30 C to +70 C)
Storage Temperature	-40 F to +185 F (-40 C to +85 C)
Withstand Voltage	3 KVAC @ 10 ma (I/P-O/P)/1 min, 2 KVAC @ 10 ma (I/P-FG)/1 min, 500 V @ 10 ma (O/P-FG)/1 min
Dimensions	1.75" H x 19" W x 14" D
Weight	8.4 lbs

BATTERY BACK UP & CHARGER

Auto-revert to Battery or Power Supplyprovided by dual Shottky diode in OR configuration
Maximum Output Current in Battery Mode40 Amps (limited by Shottky diode)
Maximum Charge Voltage.....27.6 VDC

LOW VOLTAGE DISCONNECT with RELAY

Maximum Interrupt Current / continuous current40 Amps DC
Disconnect Voltage20 VDC
Reconnect Voltage25 VDC
Disconnect Delay 2 minutes @ less than preset disconnect voltage

INSTALLER NOTES

NOTE: DO NOT block any of the cooling vents on the sides and top and always allow adequate ventilation by not installing the unit inside tightly closed spaces. Physical mounting position is not critical but the cooling vents must not be blocked.

NOTE: The outputs are **NOT** referenced to the chassis. **The Modular System can be used either positive or negative ground.**

FRONT PANEL LAYOUT

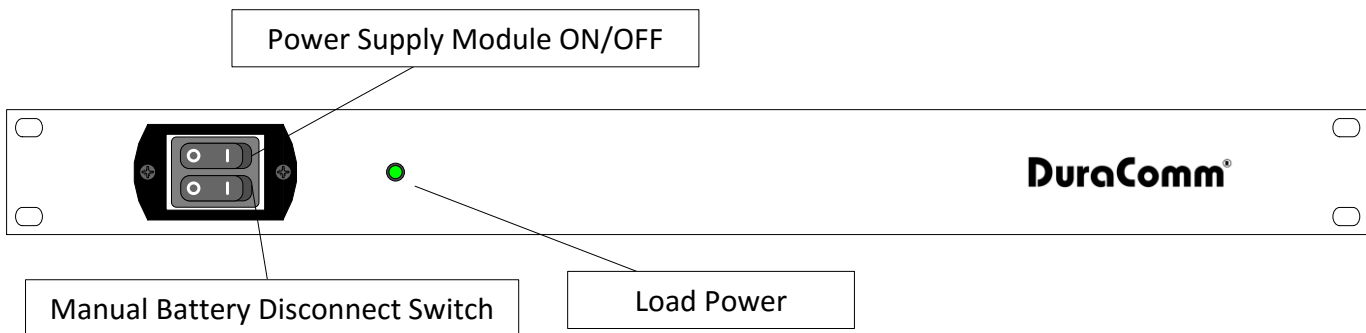

INSTALLATION BLOCK DIAGRAM

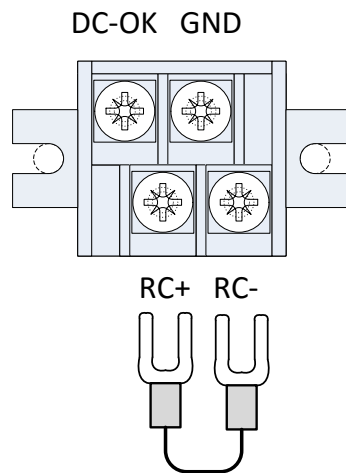

(Shown with factory jumper for PS U ON)

HE1U-2524-BBLVD Remote Control and DC-OK

Between RC- and RC+	Output Status
Switch Closed	PSU ON
Switch Open	PSU OFF

Between DC-OK and GND	Output Status
0 to 1 V	PSU ON
3.3 to 5.6 V	PSU OFF
May Also be used Open-Collector	10 mA max, 5.6 V max

HE1U-2524-BBLVD Wiring Layout

This system setup will provide continuous power to the load and maintain the battery bank with smart charger while AC power is on. There is a seamless transfer of the load to the battery when the AC power goes off. The LVD will disconnect the battery if the voltage drops below 20 VDC. The battery reconnects once AC power is restored and voltage reaches 25 VDC.

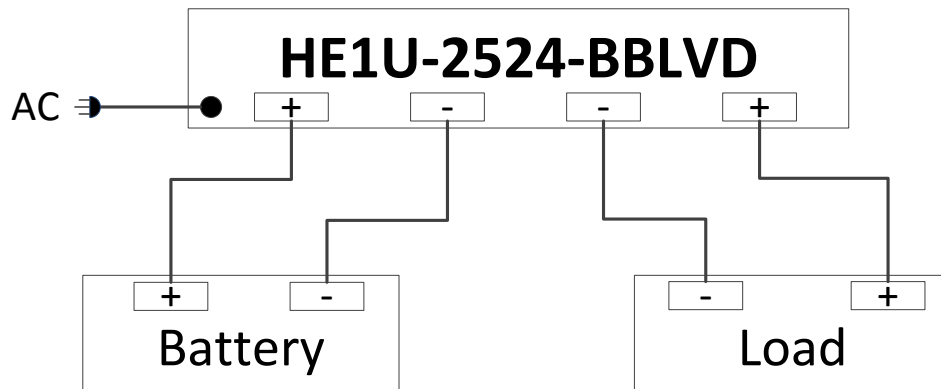

CONDUCTOR PRETREATMENT

All kinds of copper conductors can be clamped without treatment. DO NOT solder tin stranded conductors. The solder yields and fractures under high pressure. The result is increased contact resistance and excessive temperature rise. Additionally, corrosion has been observed due to the fluxes. Notch fractures at the transition from the rigid tinned part to the flexible conductors are also possible. Ferrules can be used as a protection when wiring stranded conductors. Copper ferrules prevent the current transfer from being influenced by dissimilar metals and remove the risk of corrosion. Always use the correct tool to crimp the ferrule.

RECOMMENDED COPPER WIRE SIZE FOR CURRENT CAPACITY

(Insulated Wire, Single Conductor in free air)

<u>Current Level in Amperes</u>	<u>Wire Size</u>
<7 AMPERES	20 AWG Up to 5 feet 18 AWG Up to 10 feet
14 AMPERES	18 AWG Up to 5 feet 16 AWG Up to 10 feet
20 AMPERES	16 AWG Up to 5 feet 14 AWG Up to 10 feet
30 AMPERES	14 AWG Up to 5 feet 12 AWG Up to 10 feet
40 AMPERES	12 AWG Up to 5 feet 10 AWG Up to 10 feet
50 AMPERES	10 AWG Up to 5 feet 8 AWG Up to 10 feet
70 AMPERES	8 AWG Up to 5 feet 6 AWG Up to 10 feet
100 AMPERES	6 AWG Up to 5 feet 4 AWG Up to 10 feet

LIMITED WARRANTY

DuraComm warrants to the initial end user, each power supply manufactured by DuraComm to be free from defects in material and workmanship, when in normal use and service for a period of three years from the date of purchase, from an authorized DuraComm dealer.

Should a product manufactured by DuraComm fail or malfunction due to manufacturing defect, or faulty component, DuraComm, at its option, will repair or replace the faulty product or parts thereof, which, after examination by DuraComm, prove to be defective or not operational according to specifications in effect at the time of sale to the initial end user. The product that is replaced or repaired under the provisions of this warranty, will be warranted for the remainder of the original warranty period, only, and will not extend into a new three year warranty period.

The limited warranty does not extend to any DuraComm product which has been subject to misuse, accidental damage, neglect, incorrect wiring not associated with manufacture, improper charging voltages, or any product which has had the serial number removed, altered, defaced, or changed in any way.

DuraComm reserves the right to change, alter, or improve the specifications of its products at any time, and by so doing, incurs no obligation to install or retrofit any such changes or improvements in or on products manufactured prior to inclusion of such changes.

DuraComm requires any product needing in or out of warranty service to be returned to DuraComm. All requests for warranty service must be accompanied by proof of purchase, such as bill of sale with purchase date identified. DuraComm is not responsible for any expenses or payments incurred for the removal of the product from its place of use, transportation or shipping expenses to the place of repair, or return expenses of a repaired or replacement product to its place of use.

The implied warranties which the law imposes on the sale of this product are expressly LIMITED, in duration, to the three (3) year time period specified herein. DuraComm will not be liable for damages, consequential or otherwise, resulting from the use and operation of this product, or from the breach of this LIMITED WARRANTY.

Some states do not allow limitations on the duration of the implied warranty or exclusions or limitations of incidental or consequential damages, so said limitations or exclusions may not apply to you. This warranty gives you specific legal rights which vary from state to state.

This warranty is given in lieu of all other warranties, whether expressed, implied, or by law. All other warranties, including WITHOUT LIMITATION, warranties of merchantability and fitness or suitability for a particular purpose, are specifically excluded. DuraComm reserves the right to change or modify its warranty and service programs without prior notice.

DuraComm® Corporation

6655 Troost Avenue

Kansas City, MO 64131

Phone (816) 472-5544 Fax (816) 472-0959

www.duracomm.com